

WOOD BLOCKING
CONNECTION DETAIL

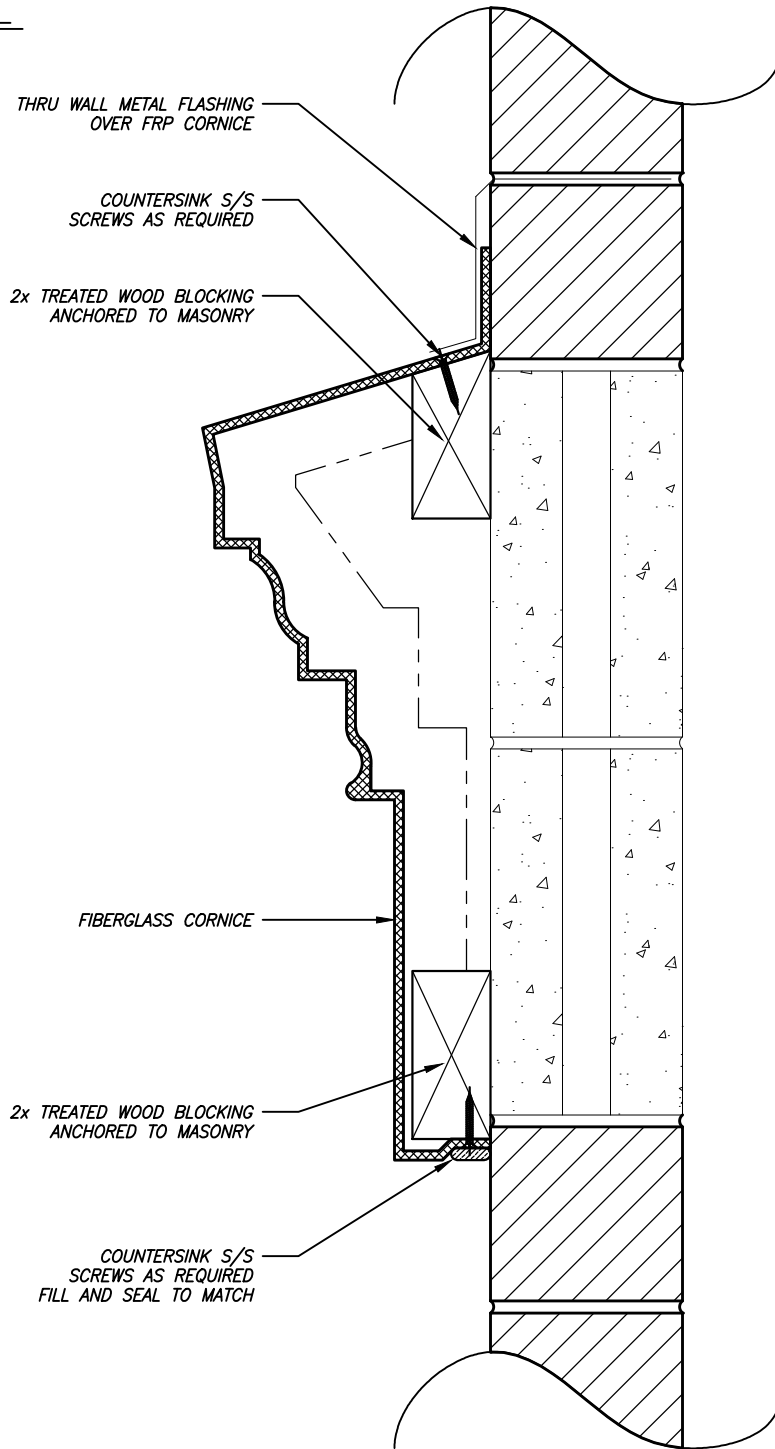

CORNICE
SHEET NO.
SD-1
2013

CONNECTIONS



ARCHITECTURAL FIBERGLASS, INC.

8300 BESSEMER AVE., CLEVELAND, OHIO 44127-1839
(216) 641-8300 - FAX:(216) 641-8150
www.fiberglass-afi.com

SUPPORT FRAMING
CONNECTION DETAIL

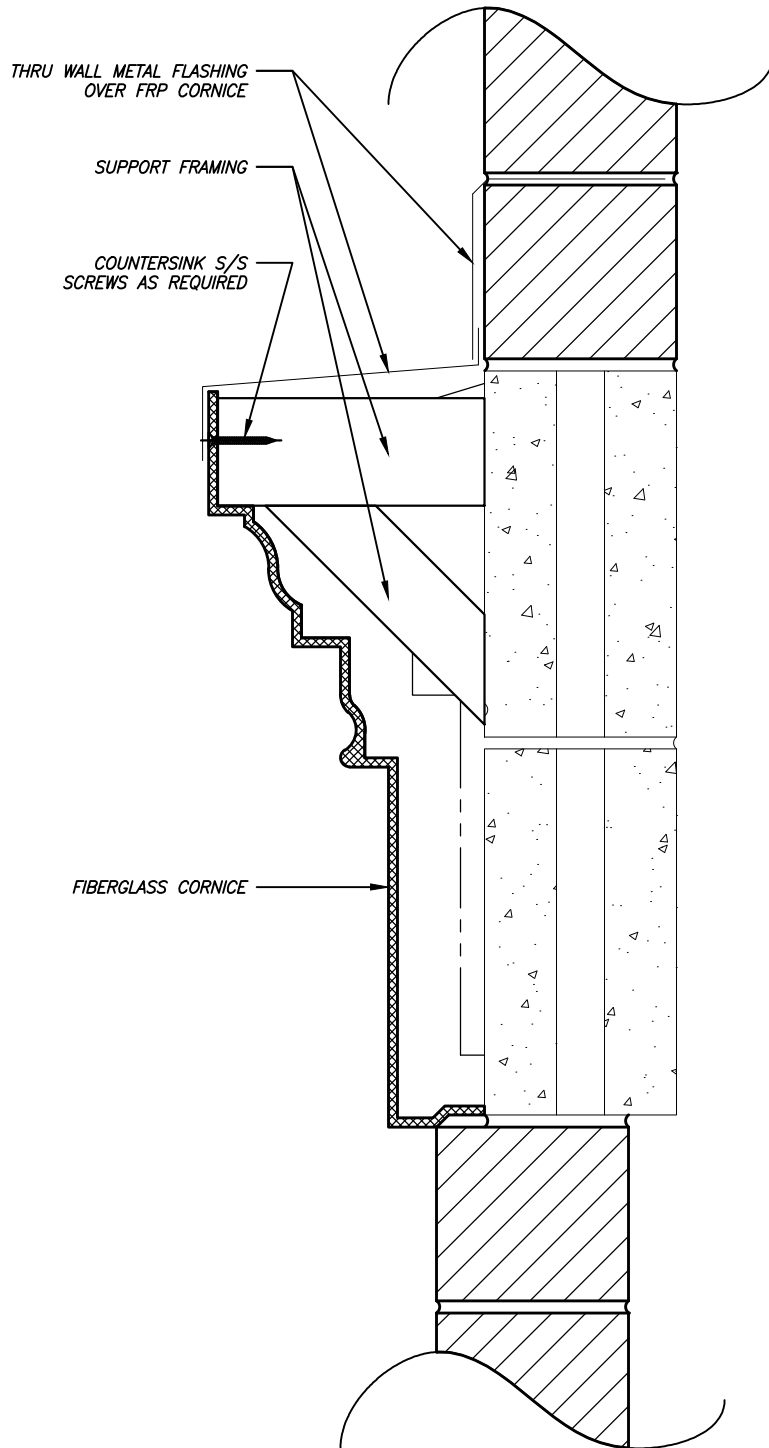

CORNICE
SHEET NO.
SD-2
2013

CONNECTIONS



ARCHITECTURAL FIBERGLASS, INC.

8300 BESSEMER AVE., CLEVELAND, OHIO 44127-1839
(216) 641-8300 - FAX:(216) 641-8150
www.fiberglass-afi.com

Z-CLIP
CONNECTION DETAIL

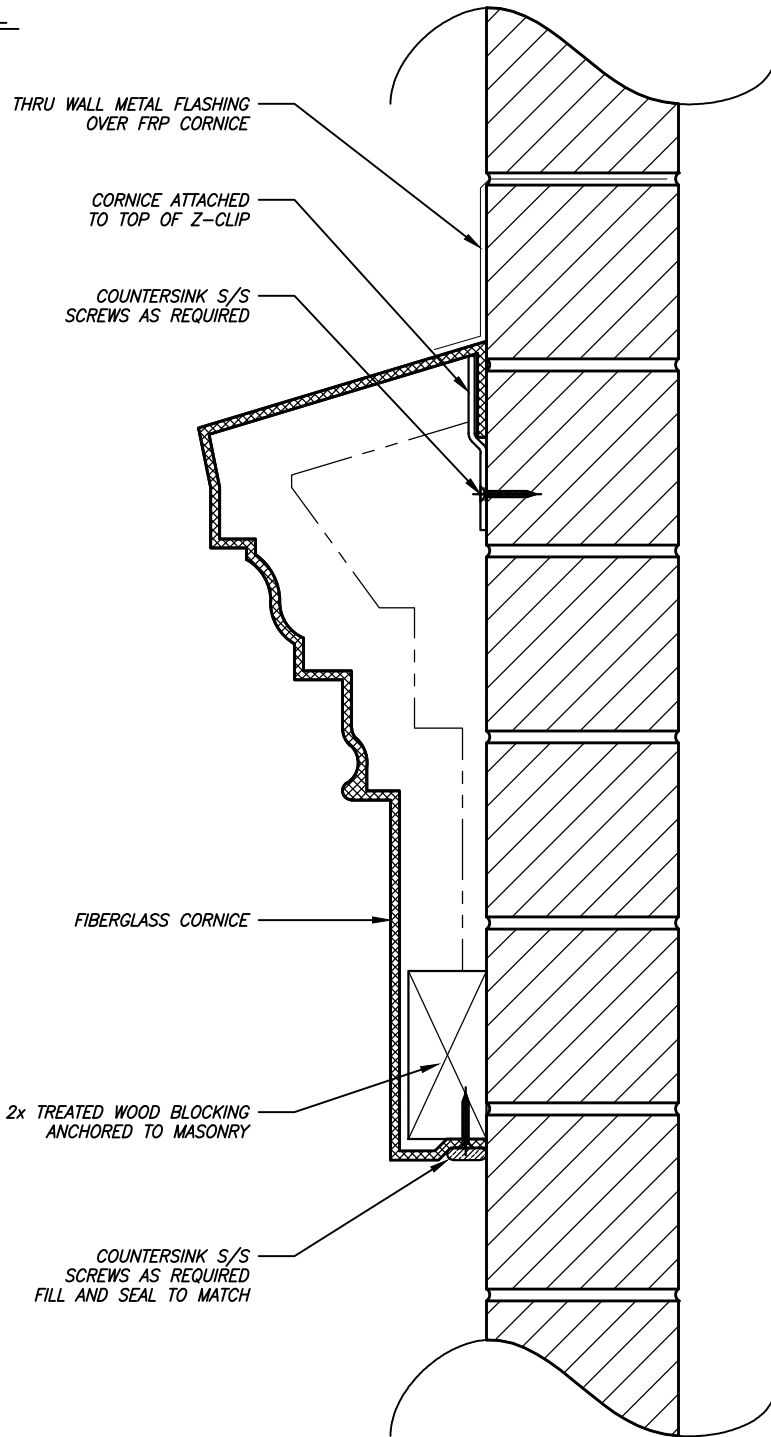

CORNICE
SHEET NO.
SD-3
2013

CONNECTIONS



ARCHITECTURAL FIBERGLASS, INC.

8300 BESSEMER AVE., CLEVELAND, OHIO 44127-1839
(216) 641-8300 - FAX:(216) 641-8150
www.fiberglass-afi.com

TYPICAL CORNICE
WITH GUTTER INSTALLATION

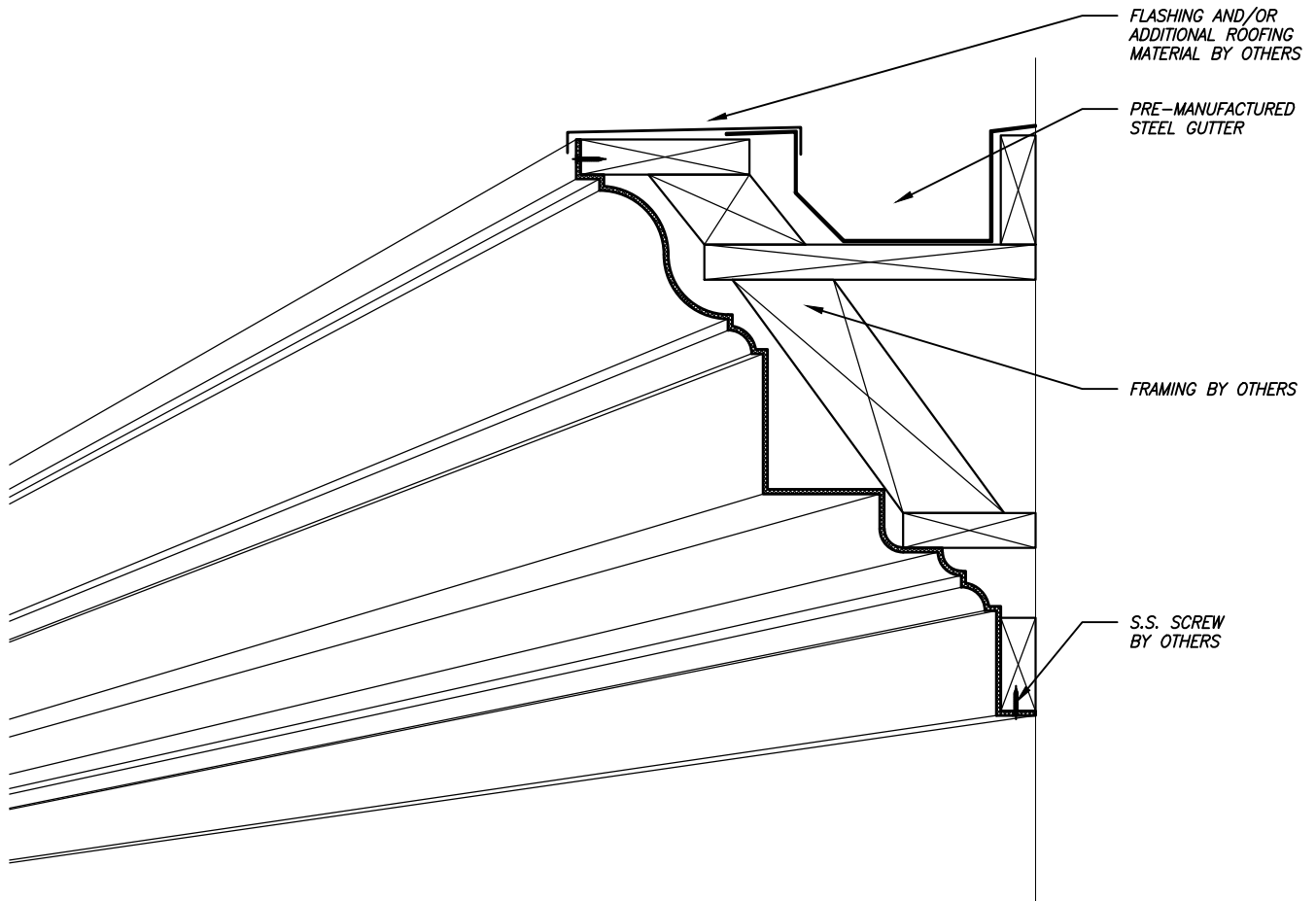

CORNICE

SHEET NO.

SD-4

2013

INSTALLATION
WITH GUTTERS



ARCHITECTURAL FIBERGLASS, INC.

8300 BESSEMER AVE., CLEVELAND, OHIO 44127-1839
(216) 641-8300 - FAX:(216) 641-8150
www.fiberglass-afi.com

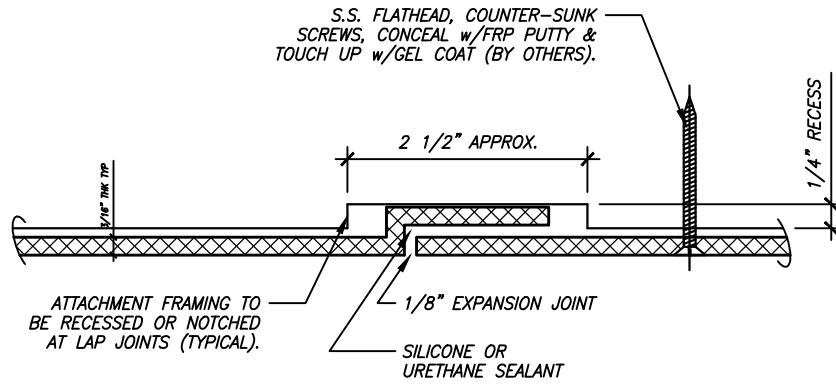

NOTE: ALL FASTENERS TO BE STAINLESS STEEL (BY OTHERS)

TYPICAL SHIP LAP DETAIL

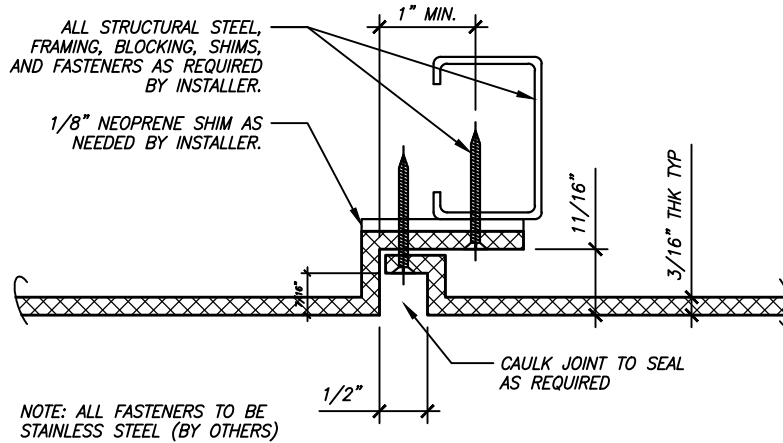

TYPICAL REVEAL DETAIL

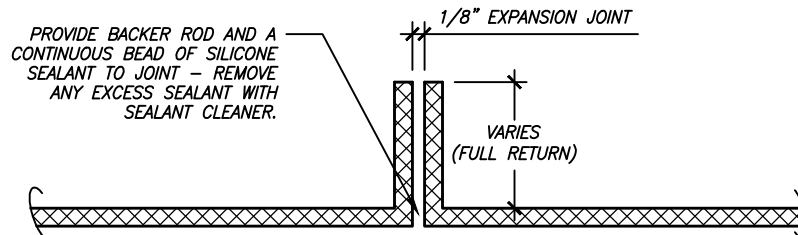

TYPICAL BUTT JOINT DETAIL

CORNICE
SHEET NO.
SD-5
2013

TYPICAL
JOINT DETAILS



ARCHITECTURAL FIBERGLASS, INC.

8300 BESSEMER AVE., CLEVELAND, OHIO 44127-1839
(216) 641-8300 - FAX:(216) 641-8150
www.fiberglass-afi.com

TYPICAL INSTALLATION FOR CORNICE WITH SHIP LAP JOINTS

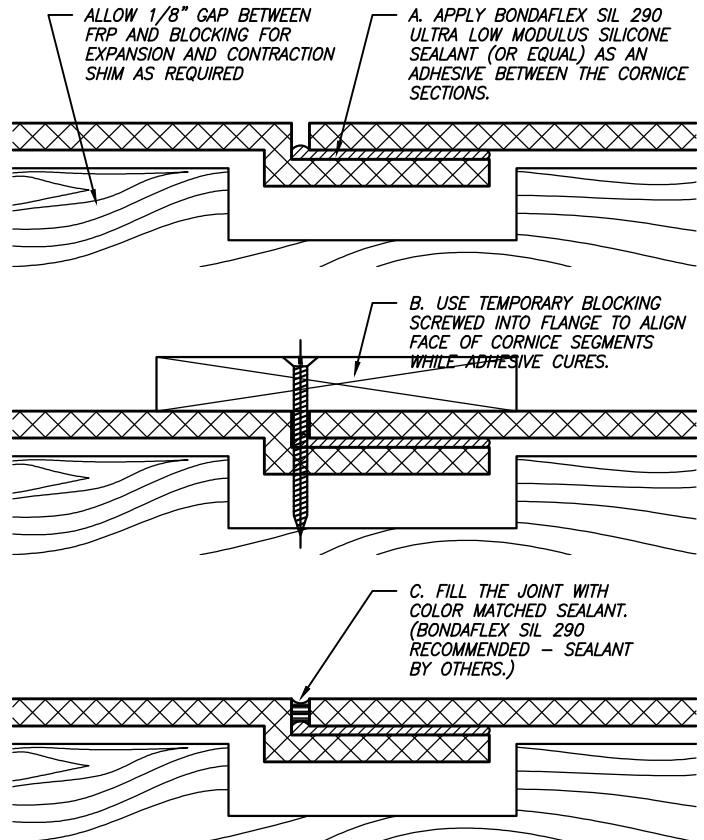
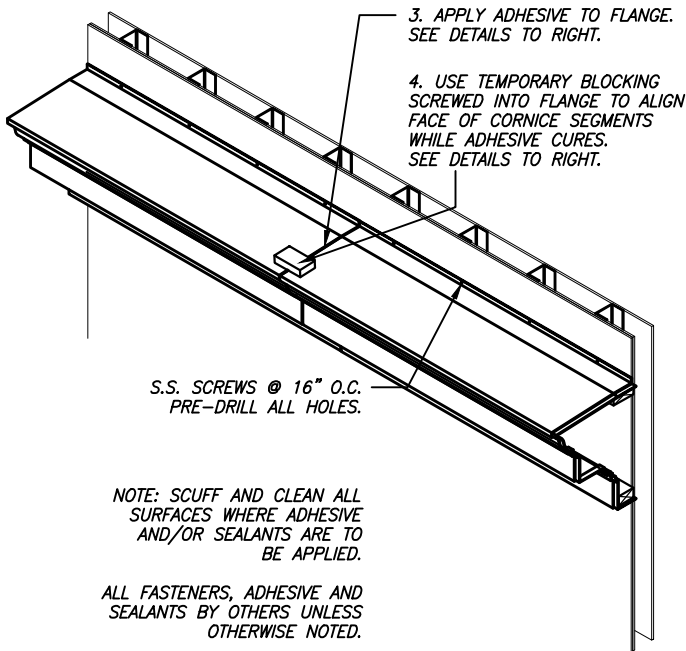
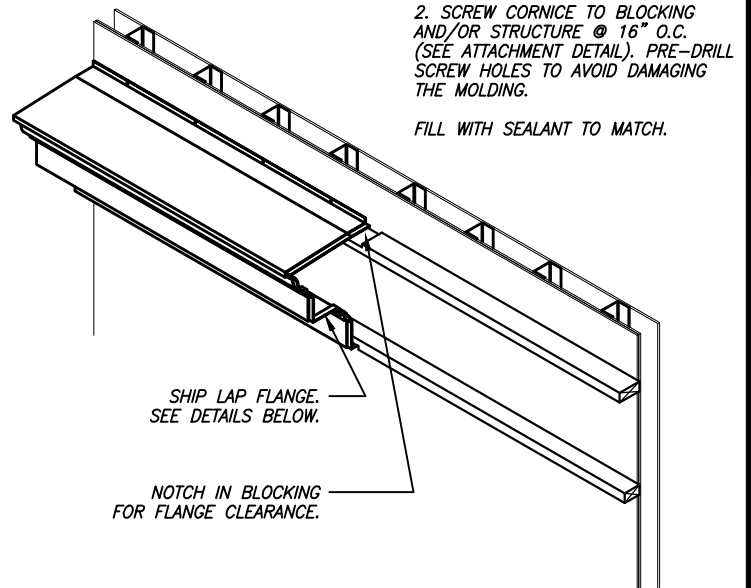
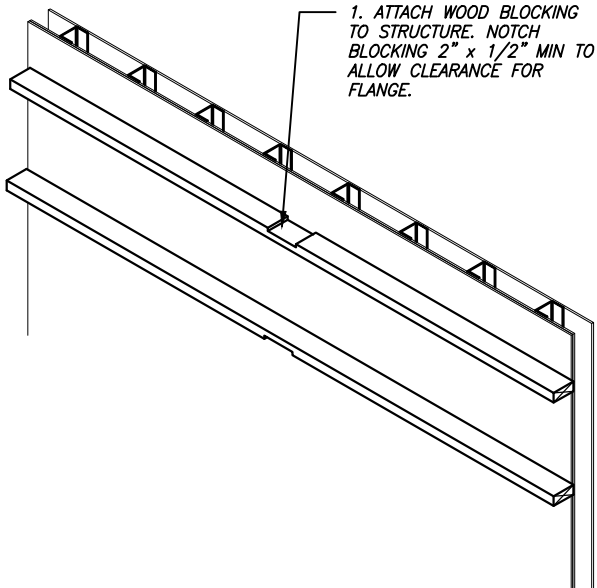

CORNICE
SHEET NO.
SD-6
2013

TYPICAL
INSTALLATION
INSTRUCTIONS



ARCHITECTURAL FIBERGLASS, INC.

8300 BESSEMER AVE., CLEVELAND, OHIO 44127-1839
(216) 641-8300 - FAX:(216) 641-8150
www.fiberglass-afi.com